



Orb



**SYRRIS**  
Orb

# Product information

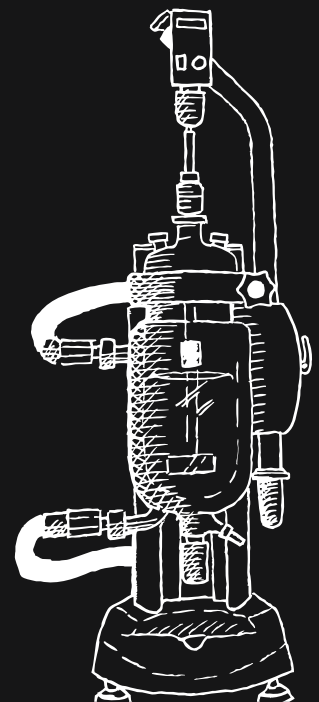

Compact benchtop jacketed reactor  
offering ultimate ease of use

# Orb

Orb is a benchtop jacketed reactor system combining excellent value and high quality construction with unique, user-friendly features and reliable performance.

Designed for daily use, Orb's intuitive and thoughtful design makes it incredibly easy to use. Orb offers rapid height adjustment and two clamp sizes to accommodate a wide

range of vessels from 100 mL to 10 L which can be interchanged rapidly and seamlessly. The system can be used over a wide temperature range for all your lab's chemistry needs. A wide selection of accessories and upgrades for automation are available.

[syrris.com/orb](http://syrris.com/orb)



## Why Orb?

Due to its modular design, wide vessel range, and wide temperature limits, Orb can be used in many applications including process development and optimization, advanced synthesis, crystallization, automated synthesis, and more.

Ease of use is Syrris' main design philosophy.

1. **Easy scale-up with a wide vessel range**
2. **Work at your height with easy, tool-free adjustment**
3. **Avoid spills with rapid oil pipe connection and oil drain**
4. **Quick clamp system for fast and safe vessel loading**
5. **Save lab space with one Orb frame for all vessels**
6. **Easy, simple, tool-free motor adjustment**

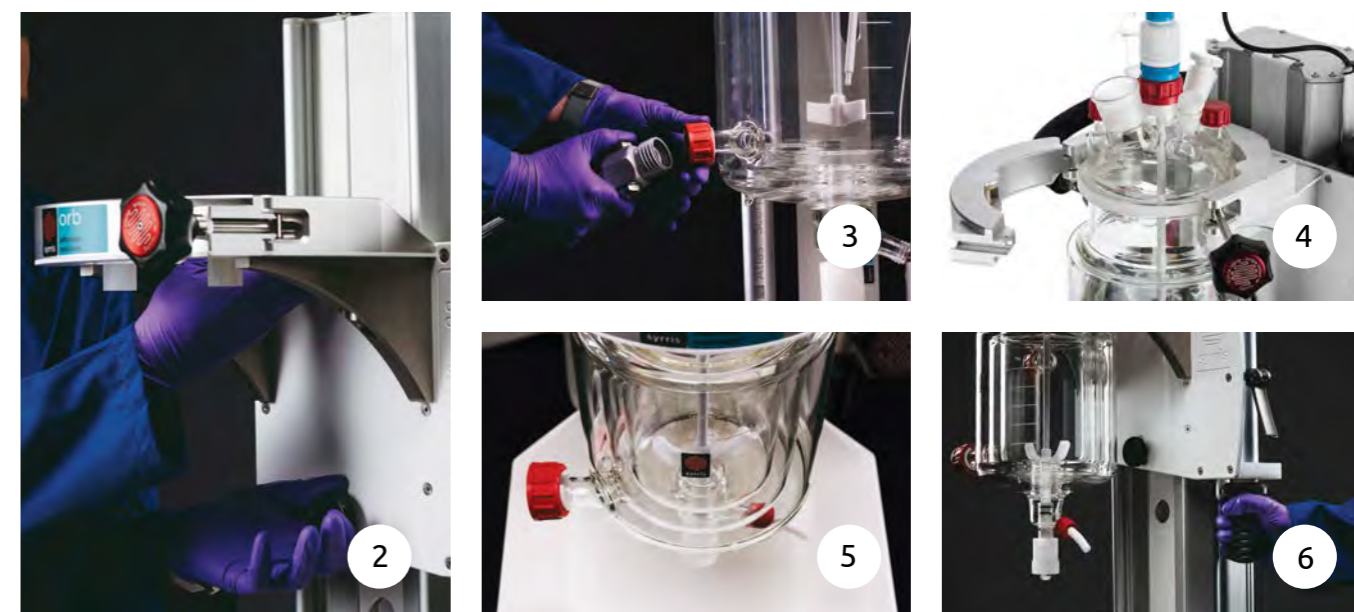

**“ Our passion is to design products to make chemists' lives easier. The aim was to create a product with excellent performance at an attractive price.... and we believe Orb does this.”**

**Dr. Omar Jina, Chief Commercial Officer**



# Features

## Condensers

A wide variety of condensers are available

## Lids

The Orb Lid is available in two sizes (DN100 & DN150). Ports are included for baffles, solid addition, probes, and condensers, with custom options available

## Oil Pipe Tidy

The Oil Pipe Tidy is easily attached to the main plate on the Orb Clamp and allows leak-free storage of your oil pipes when changing vessels

## Baffles

Orb baffles are available to further improve mixing. Top-loading and removable for easy insertion and cleaning

## Outlet valve

Syrris' spring-loaded outlet valves ensure leak-free operation at all temperature ranges and prevent accidental damage through over-tightening

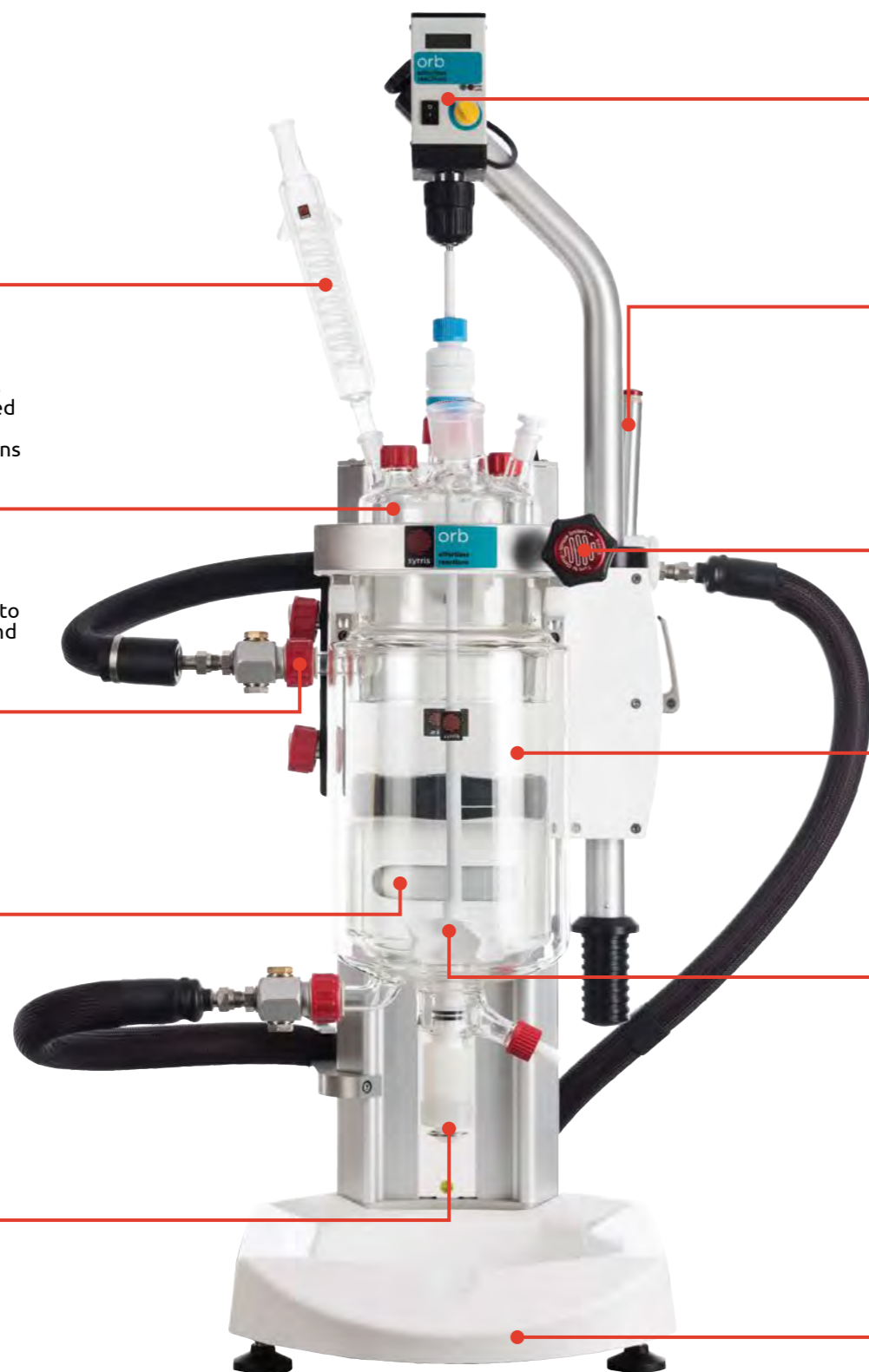

## Stirrer motors

High-specification motors from leading manufacturers offer performance and durability for the most demanding applications

## Oil Drain Unit

To limit mess when changing vessels, Orb has an optional Oil Drain Unit for easy and mess-free draining of vessel jackets

## Clamp

The patent-pending Orb Clamp is available in two sizes (DN100 & DN150) and allows rapid vessel changes with safe sealing and support. The unique design holds the vessel in place even when completely undone

## Vessels

Jacketed vessels are available from 100 mL to 10 L (with vacuum jacket option up to 5 L). Custom options are also available

## Stirrers

Orb stirrers are available in anchor, Pitched Blade Turbine, and retreat curve impellor as standard. Custom stirrer options and adjustable impellers are also available

## Base Frame

The Orb Base Frame is a rugged and adaptable frame which accommodates all vessel sizes in the Orb family

# Designed for you

Designed with simplicity and flexibility in mind, Orb is the jacketed reactor system combining high performance and excellent value.

## Wide range of vessels

One Orb, multiple vessels. Orb allows vessels from 100 mL to 10 L to be utilized on one system. Single jacketed (up to 10 L) or vacuum jacketed (up to 5 L) reactors in torispherical or round bottom profiles (up to 5 L) can be used on the system. Torispherical reactors are the ideal choice for your scale up studies

## Quick vessel changes

Orb's unique vessel clamp, oil drain function, and quick connections allow vessels to be interchanged in minutes, providing the utmost in flexibility

## Simple stirrer lift

Orb's innovative stirrer motor lift allows the stirrer motor to be easily lifted and rotated out of the way to give full access to the lid and ports. The stirrer motor can then be relocated without the need for further alignment

## Tool-free height adjustment

The unique frame allows you to adjust the Orb vessel height without any tools so you can work at a level that is suitable for you

# The importance of accurate temperature control

Round-bottom flasks have long been the mainstay of almost all chemistry labs, but they come with inherent problems that make them unsuitable for more challenging chemistry.

Limited temperature ranges, lack of repeatability, and the need for constant experiment supervision all fly in the face of the ever-growing pressure on synthetic organic chemists to develop innovative chemical reactions and compounds quickly and efficiently. Jacketed reactor systems help combat these issues and enable chemists to perform better chemistry, more efficiently than ever.

## The challenge: Accurately maintaining reaction temperatures

Round-bottom flasks are generally limited to 4 temperatures;

- Reflux
- Room temperature (can vary significantly with changes in environment)
- 0 °C (can be achieved with an ice bath)
- -78 °C (a mixture of acetone and dry ice)

Flasks make life difficult if your chemistry requires a different temperature, as most optimized processes do. The variations in temperature when manually controlled, although small, can dramatically impact the reaction yield and reproducibility of results.

## The solution: Pinpoint accuracy in temperature control with jacketed reactor vessels and circulators

Jacketed reactors accurately control the temperature of their contents through the use of a “jacket” of heating/cooling fluid which is controlled to fractions of degrees by oil circulators. Not only does this enable much more consistent reaction temperatures, but it also provides easy temperature “ramping”—something that’s virtually impossible with round-bottom flasks.

This advanced temperature control allows chemists to work at a huge range of temperatures and therefore access more complex chemistries. The accuracy also enables far greater repeatability and reproducibility of results.

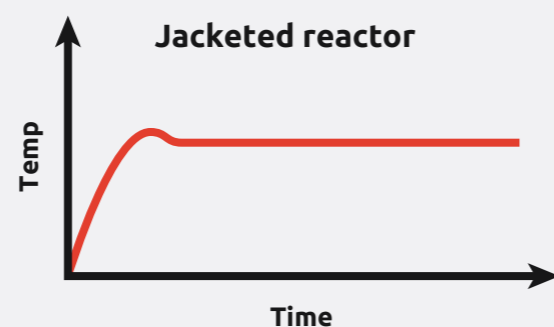
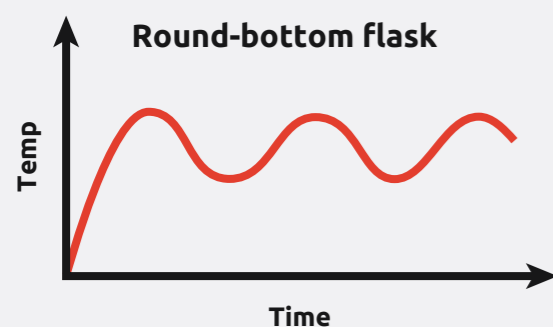

# Intelligent dosing

Many processes require accurate dosing of reagents. Syrris provides a multitude of dosing options to suit your process requirements, including volumetric, sensor-based, and gravimetric-centered dosing.

Atlas Syringe Pumps are versatile chemistry pumps featuring advanced dosing protocols including pH control, temperature-dependent dosing, and autosampling with flow rates from 0.5  $\mu\text{L}$  to 200 mL/min. The pumps can be operated in standalone/manual mode, or controlled automatically using automation software. Atlas Syringe Pumps can be used as standalone pumps with Orb (or your existing batch reactors), or

controlled by Atlas PC Software 1 for fully automated synthesis.

## Multiple dosing options, including;

- Temperature-dependent dosing
- pH-controlled dosing
- Autosampling of up to 6 samples with each syringe/valve

## Multiple control modes, including;

- Dual Dosing Mode enables two reagents to be dosed independently
- Continuous-Dosing Mode enables refilling of one syringe while the other doses
- Autosampling Mode allows one reagent to be dosed while collecting samples from the process at predefined times



# Case Study

## Reproducible scaling of gold nanoparticles in Brazil with Orb

Prof. Ricardo Aucélio  
Pontificia Universidade Católica

**Researchers at a University in Brazil have been using the Orb Jacketed Reactor system to scale up their gold nanoparticle synthesis. Prof. Ricardo Aucélio from Pontificia Universidade Católica research looks at specialist nanoparticles for use in analytical tools. They purchased the Orb system in an attempt to overcome the scaling issues of moving from a round bottom flask. Prof. Ricardo Aucélio said:**

“The reactor was purchased with CNPq resources in order to produce gold nanoparticles in aqueous medium at room temperature. Prior to the acquisition of the reactor, these reactions used to be done in round bottom flasks on magnetic stirring plates. However, we had a recurrent problem regarding the repeatability of the nanomaterial quality, due to the difficulty of adjusting the frequency of agitation, especially when we promoted the modification of the volume (in mL) of the synthesis.

“Using small volumes such as 30 mL the results were adequate, however, when we needed to scale the synthesis to 180 mL (retaining the same proportions of reactants) the repeatability of the measured optical signal of the AuNPs became inadequate. On the other hand, when we started making these reactions in Orb this problem no longer exists. The jacketed vessels present an appropriate geometry that assists in the adequate homogenization of the reaction medium, promoted by the mechanical agitator. In this way, we are constantly using the reactor and the research group is fully satisfied with its performance.

“The Orb system is very simple to operate, compact and robust. We are using it for the synthesis of gold nanoparticles (AuNPs) capped with different chemical binders. As the system is very easy to operate, my masters’ and doctoral students already have full autonomy to use the system.”

## Accessories

Orb has been designed by chemists who understand the issues chemists face with jacketed reactor systems. Orb is easy to customize to your exact requirements; simply choose from a range of vessel sizes and types, baffles, probes, sensors, stirrers, stirrer motors, and other glassware accessories.

### Jacketed reactors

Choose from a range of glass jacketed and vacuum jacketed reaction vessels. All Syrris reactor vessels are manufactured at our state-of-the-art glass manufacturing site.



Jacketed

10 L, 20 L, 30 L, and 50 L



Vacuum Jacketed

10 L, 20 L, and 30 L



**Custom reactors are also available**

### Lids

Orb lids are available in borosilicate glass, PTFE, and stainless steel in various sizes: DN100 (EU and US) and DN150 (EU and US). **Custom lids are also available.**

### Probes and Nodes

Wide range of probes and nodes available in various lengths, including temperature, turbidity, and pH. Orb probes and nodes can be used in conjunction with the Atlas Syringe Pump for temperature-controlled and pH-controlled dosing.

### Stirrers

PTFE, glass, and stainless steel stirrers in a variety of geometries are available.



Anchor



Pitch blade turbine



Retreat curve impellor



**Custom stirrers are also available**







### Stirrer motors

High torque (200 N/cm), torque feedback, remote control, and digital display stirrer motors up to 800 rpm are available.

### Automation upgrade

Orb (and all other manual jacketed reactors) can be upgraded to full automation through Atlas PC Software 1, Syrris’ powerful and easy-to-use automation platform. Reaction automation enables true walk-away chemistry and offers a number of safety, repeatability, and accuracy benefits to chemists.

# Specifications

	Vessel range	100 mL to 10 L * / 100 mL to 5 L**
	Temp. range	-90 to 250 °C***
	Pressure range	Vacuum ( $\leq 50$ mbara****) to 250 mbar
	Stirrer motor rpm	500 continuous / 800 intermittent
	Stirrer motor torque	Up to 200 Ncm
	Dosing options	0.5 $\mu$ L to 20 mL/min (Atlas Syringe Pump) 5 $\mu$ L to 200 mL/min (Atlas XL Syringe Pump)

# Dimensions

	h (mm)	w (mm)	d (mm)
100 mL to 2 L vessels	975 <sup>^</sup>	406 <sup>^^</sup>	570
5 L vessels	1065 <sup>^</sup>	406 <sup>^^</sup>	570
10 L vessels	1245 <sup>^</sup>	406 <sup>^^</sup>	570
Atlas Syringe Pump	255	163	240
Atlas XL Syringe Pump	355	163	258

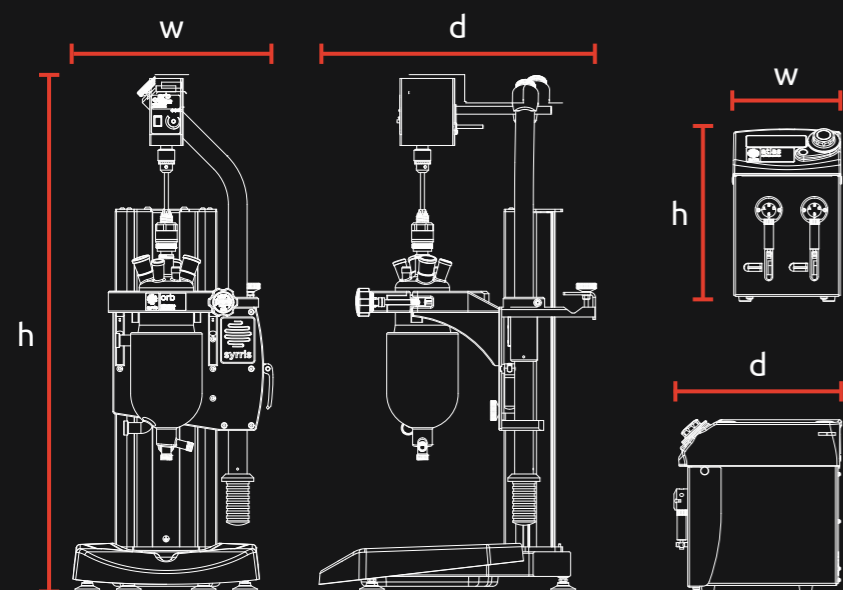

- \* Jacketed vessels
- \*\* Vacuum jacketed vessels
- \*\*\* Normal temperature range is -40 to 200 °C. Temperatures outside of this range require an upgrade kit.
- \*\*\*\* Lower vacuum is achievable with upgraded parts
- ^ Allow additional 80 mm for motor lifting.
- ^^ Please allow for oil pipes. Dimension is for system only.

All dimensions in mm. Please allow a tolerance of +/- 20 mm.

# Why choose Syrris?

## Custom parts

We understand that all labs are different, so while we've designed our products to be as flexible as possible, sometimes you'll need something unique to your laboratory or application.

Many custom parts are simple variations on existing parts—shorter stirrer shafts or extra ports on a lid, for example. Some customers, however, require far more complex custom parts for their jacketed reactors or flow chemistry systems, such as automated bottom outlet valves (BOVs), unique stirrer designs, or custom vessels.

Syrris' ability to create unique custom parts is one of the main reasons chemists around the world choose Syrris for their needs.

## Support

Syrris is on hand to help when you need it. From feasibility studies and proof of concept, through to on-site support by a Syrris engineer, our team are experienced chemists and are supported by a network of trained distributors in over 40 countries.

Built by our UK production team to the highest standard, with chemically resistant materials, Syrris products ensure years of continued service. A 1-year warranty as standard and the option to extend this further for complete peace of mind.

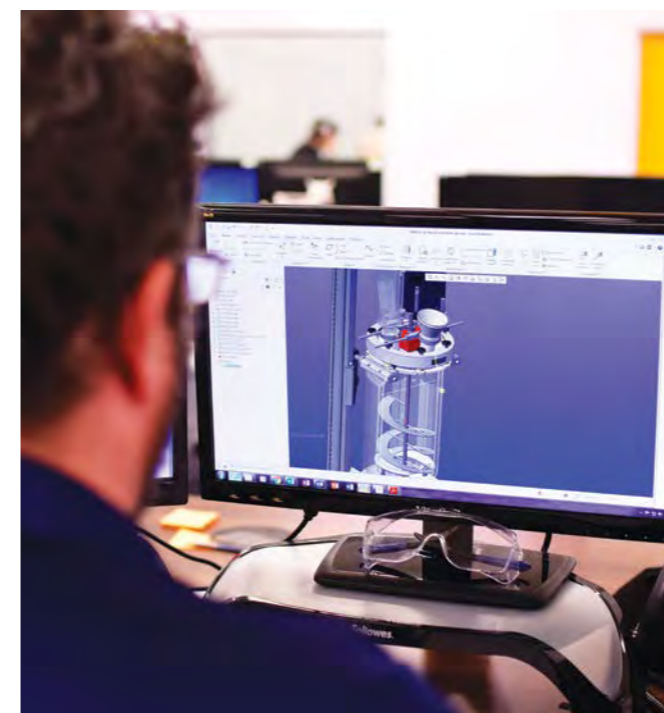

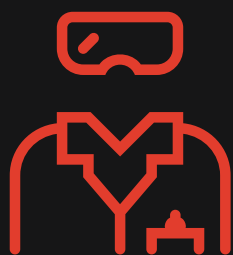

//

The Orb system is simple to operate, compact, & robust. My Masters and Doctoral students already have full autonomy to use the system"

Prof. Ricardo Aucélio, Pontificia Universidade Católica, Brazil

//

One key to our success with the system, apart from the strength of the product itself, is the highly responsive nature of Syrris as a company"

Dr. Sunil S. Nadkarni, VP, Product Development Torrent, India



# 400

## Publications

Syrris products have been cited in over 400 peer-reviewed publications, demonstrating their viability for real-world chemistry

# 40

## Distributors

Syrris works in partnership with over 40 distributors worldwide, offering expert knowledge and local support

# 1000s

## of Users

Thousands of chemists and chemical engineers use Syrris products in their ground-breaking research and development, including at the world's top 20 pharmaceutical, chemical, and food and fragrance companies

# Get in touch

**UK Head Office (Europe, S.E. Asia, Australasia, China, Middle East, Africa)**

t: +44 (0)1763 242555  
e: info@syrris.com  
w: syrris.com

**Japan Office**

t: +81 45 263 8211  
e: info@syrris.co.jp  
w: syrris.co.jp

**North America Office**

t: +1 (617) 848 1211  
e: info-usa@syrris.com  
w: syrris.com

**India Office**

t: +91 22 256 00 262  
e: info@syrris.com  
w: syrris.com

**Hanoi Office**

t: +84 (0)24 66553474  
e: info@syrris.com  
w: syrris.com

Distributore per l'Italia:



Contattaci:  
alfatest@alfatest.it

alfatest.it  
alfatestbio.it  
alfatestlab.com