

JACOMEX



HIGH SECURITY GLOVE BOX UNDER FILTERED AIR



NUCLEAR



RESEARCH



INDUSTRY

GLOVEBOX SYSTEM STANDARD FEATURES

- ISO 10648-2 highest leaktightness class 1
- Stainless steel (304L or 316L shell and chassis)
- Enhanced decontaminability and cleanability
- Automated mechanical ventilation regulation & safety valves
- Double inlet and outlet HEPA filtration
- Bag In Bag Out filter boxes (BIBO)
- Ventilated airlock systems
- Industry standard feedthroughs, docking systems, transfer and waste bags



BEYOND THE STANDARD FOR CRITICAL APPLICATIONS

- Dedicated JACOMEX project and engineering team
- Safety Substantiation (Nuclear, seismic, ventilation)
- Automation, data log and transfer
- Human Factor, Organization and Technological
- Risk assessment
- Compliance with ATEX environment in/out
- Gamma / Neutron radiation shielding
- Acids resistant coatings (ALAR)
- Over Under Pressure Protection Systems (OUPPS)
- Active confinement for accidental conditions
- Special filtrations : Acids, iodine, gases, ULPA

VENTILATION SKIDS FILTRATION



- VMR regulation valves
- VMS safety valves
- Filter Box (BIBO)
- Vacuum Breaking Valve
- Acid trap
- Iodine filtration
- Butterfly valves
- Autonomous ventilation blower

TRANSFER SOLUTIONS



- Feedthroughs
- Drum docking systems
- Ventilated airlocks
- Double door transfer ports
- Waste bag ports
- Rapid Transfer Ports (RTP)

SYSTEM INTEGRATION



- Furnaces
- Liquids sampling
- High precision weighing
- Powder processing
- Waste management
- Robotic arms
- Special customer processes

QUALITY CERTIFICATIONS

- ISO 9001 : 2015
- ISO 19443 compliant and approved QA program
- CEFRI certified
- ISO 10648-2 - Class 1
- ISO 3834 - Welding WPQ, PQR, certified for TIG, YAG
- Construction codes : ISO, RCC-M/ MR, ASME, AGS, ISO 10648-1
- Active member :

DIMENSIONS AND DESIGN : Gsafe

CUSTOM DESIGN UPON REQUEST

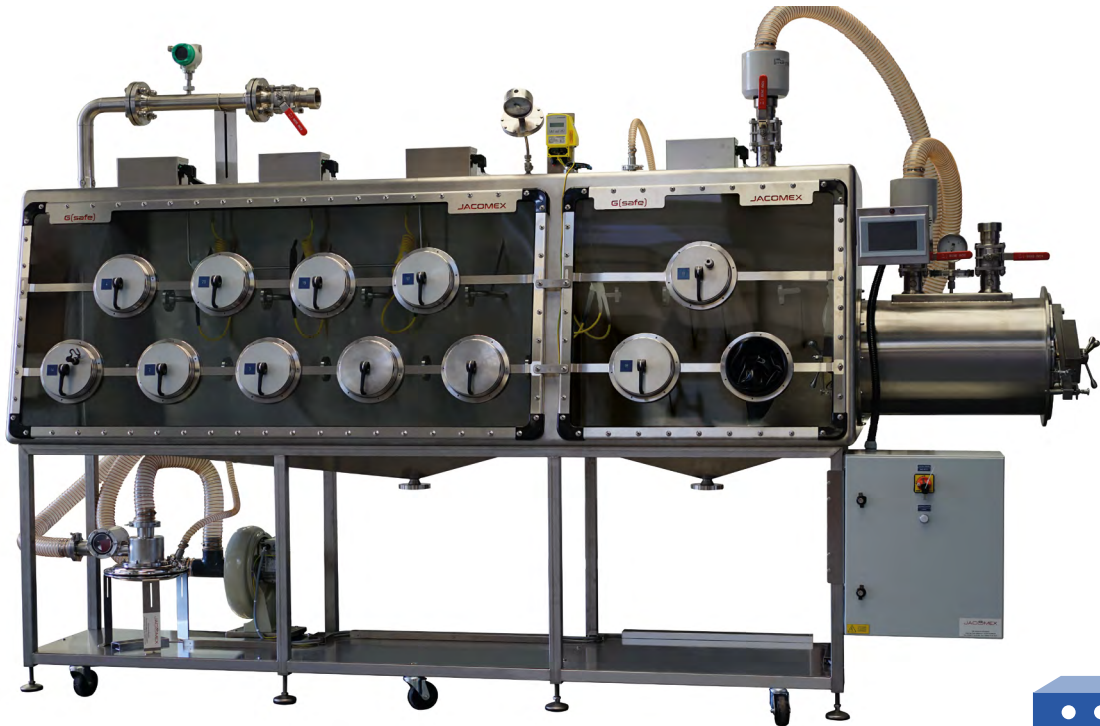

STANDARDIZED DESIGN

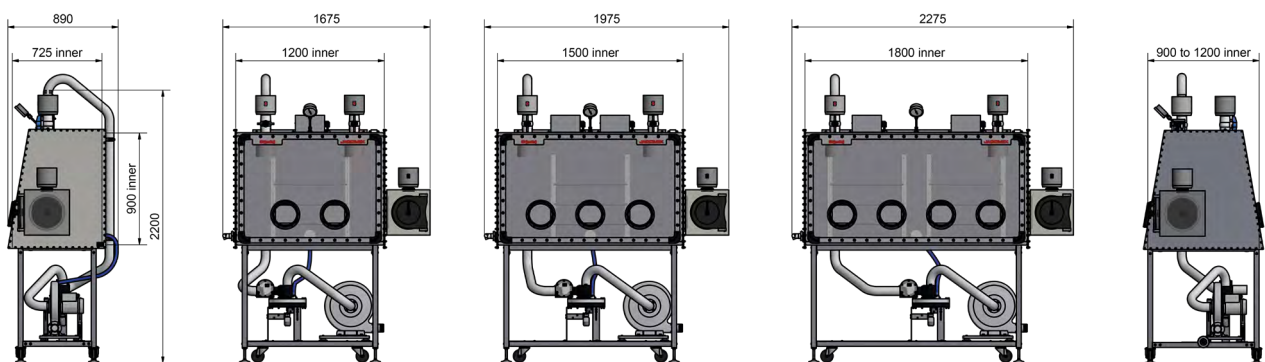

Distributore per l'Italia:

ALFATEST
STRUMENTAZIONE SCIENTIFICA

Contattaci:
alfatest@alfatest.it

alfatest.it
alfatestbio.it
alfatestlab.com